



TPC190-SB

H61



Optional
Optical Drive

Features

- 19" 1280x1024 TFT LCD Panel with Touch Screen
- 2 2.5" SATA drive bays
- 2 USB 2.0 at the front panel for easy access
- 5 function keys at the front panel
- Built-in antenna for optional Wi-Fi
- VESA/Wall/Panel Mount

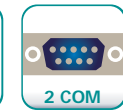
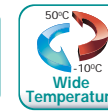

Panel



Built-in antenna

Front View

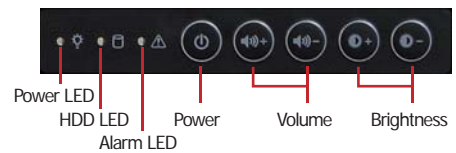

Function keys (standard)

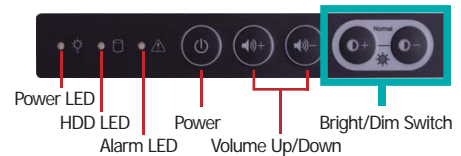

Bright/Dim Switch for Sunlight Readable Display (optional)

Press the buttons simultaneously to switch the screen between bright and dim.

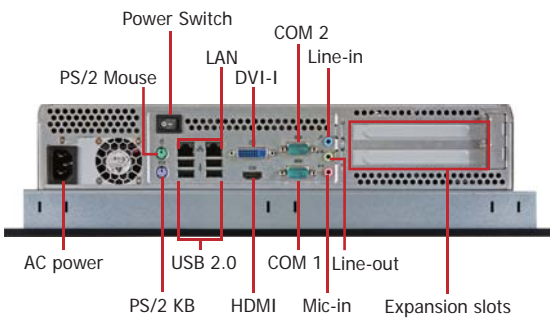

Bottom View

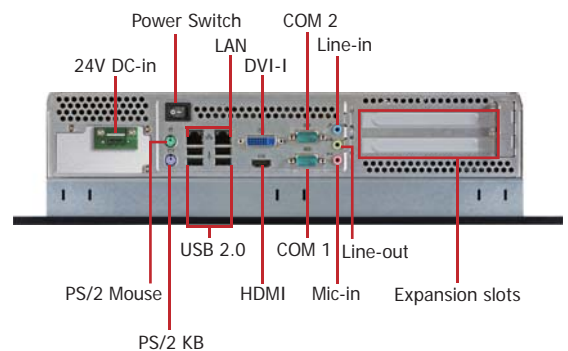

TPC190-SB

► Specifications

PROCESSOR SYSTEM

- Processors:
 - 3rd generation Intel® Core™ processors
 - 2nd generation Intel® Core™ processors
- Supports up to 65W TDP
- Intel H61 Express chipset

MEMORY

- Two DDR3 1333/1600MHz SODIMM sockets (3rd generation processors)
 - Two DDR3 1066/1333MHz SODIMM sockets (2nd generation processors)
- Supports up to 16GB system memory

LCD and TOUCH SCREEN

- 19" 1280x1024 TFT LCD panel with touch screen
- Supports 5-wire Resistive Touch
- 50,000 MTBF LED backlight
- Brightness (cd/m²): 350

GRAPHICS

- Intel® HD Graphics
- Display ports: HDMI and DVI-I
- HDMI and DVI-I display resolution up to 1920x1200

STORAGE

- 2 2.5" SATA drive bays
 - SATA 2.0 port with data transfer rate up to 3Gb/s
- 1 optical drive bay (optional)

ETHERNET

- 1 Intel W82579LM Gigabit Ethernet Controllers
- 1 Intel W82574L Gigabit Ethernet Controllers

AUDIO

- Realtek ALC886 5.1-channel High Definition Audio
- Two 3W speakers (left and right sides)

COM

- 1 RS232/422/485 COM port
- 1 RS232 COM port

USB

- 2 Type A USB 2.0/1.1 ports at the front panel
- 4 Type A USB 2.0/1.1 ports at the bottom

I/O

- Front
 - 2 Type A USB 2.0/1.1 ports
 - 5 function keys: power, volume, brightness and marine application
 - 3 LED indicators: Power, HDD, Alarm
 - 1 built-in antenna
- Bottom
 - 1 DB-9 RS232/422/485 COM
 - 1 DB-9 RS232 COM
 - 1 PS/2 keyboard
 - 1 PS/2 mouse
 - 4 Type A USB 2.0/1.1
 - 3 audio jacks: Mic-in, Line-in, Line-out
 - 2 RJ45 LAN with LEDs
 - 1 DVI-I
 - 1 HDMI
 - 1 power switch

EXPANSION

- 1 PCIe x1 and 1 PCI (X100-3PE2)
- 2 PCI (X100-2P1M)
- 2 Mini PCIe
 - Supports PCIe and USB signals for Wi-Fi module
 - Supports half/full size Mini PCIe card

POWER

- Power input voltage
 - Standard: ATX power type, AC 100-240V, 3.5A, 250W
 - Option: 24V DC-in 3-pole terminal block
 - Available upon request: 12V and 30V DC-in 3-pole terminal block

COOLING SYSTEM

- Smart fan system control suitable for quiet environments

ENVIRONMENT

- Temperature
 - Operating: -10°C ~ 50°C
 - Storage: -20°C ~ 60°C
- Relative Humidity
 - 90% RH at 50°C, 1 week
- Corrosion
 - 4 periods of 7 days at 50°C with 90-95% relative humidity after 2 hours salt spray or waiver

VIBRATION

- Operating: 1G, 5~500Hz
- Non-operating: 1.5G, 5~25Hz
- IEC 68-2-64 compliant

SHOCK

- Operating: 3G peak acceleration (11 msec. duration)
- Non-operating: 10G peak acceleration (11 msec. duration)
- IEC 68-2-27 compliant

FRONT PANEL PROTECTION

- IP65 (Dust Tight; Water Proof protection)

CONSTRUCTION

- Aluminum front bezel
- Rear panel: sheet metal

MOUNTING

- VESA mount: 75x75 and 100x100
- Wall mount bracket (option)
- Panel mount: mounting clamp (option)

DIMENSIONS

- 472mm x 391mm x 116mm (W x H x D)

WEIGHT

- 10.2 kg

OS SUPPORT

- Windows XP Professional x86 & SP3 (32-bit)
- Windows XP Professional x64 & SP2 (64-bit)
- Windows 7 Ultimate x86 & SP1 (32-bit)
- Windows 7 Ultimate x64 & SP1 (64-bit)
- Windows 8 Enterprise x86 (32-bit)
- Windows 8 Enterprise x64 (64-bit)



TPC190-SB

► Dimensions

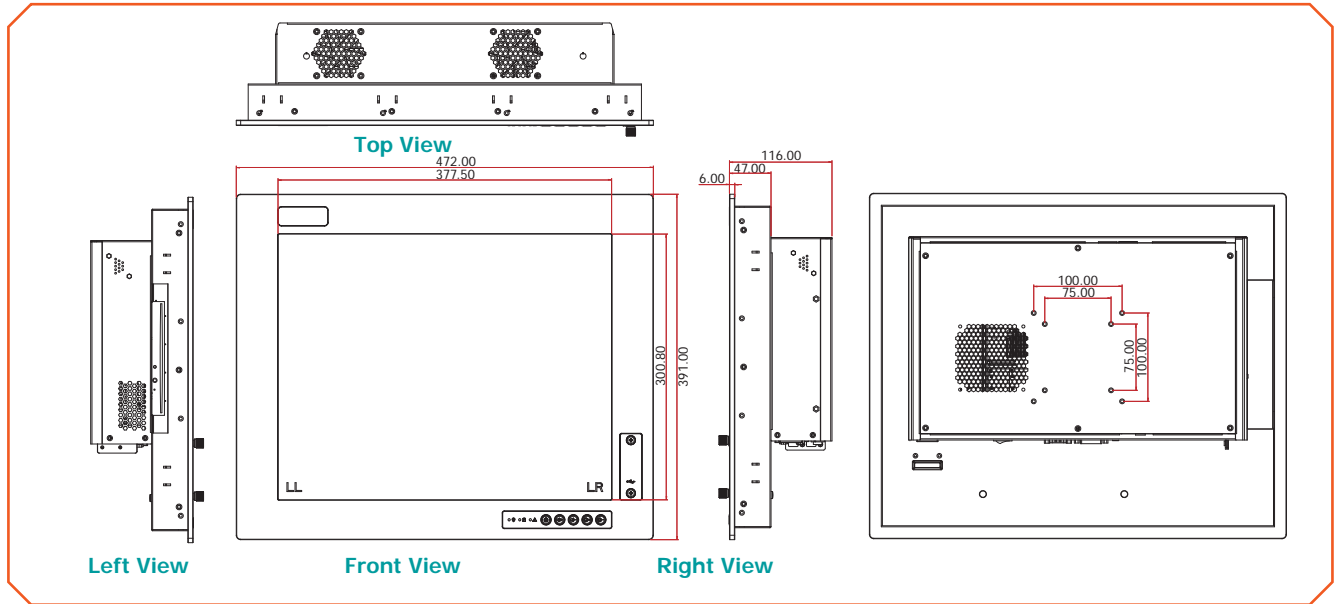

► Wall Mounting

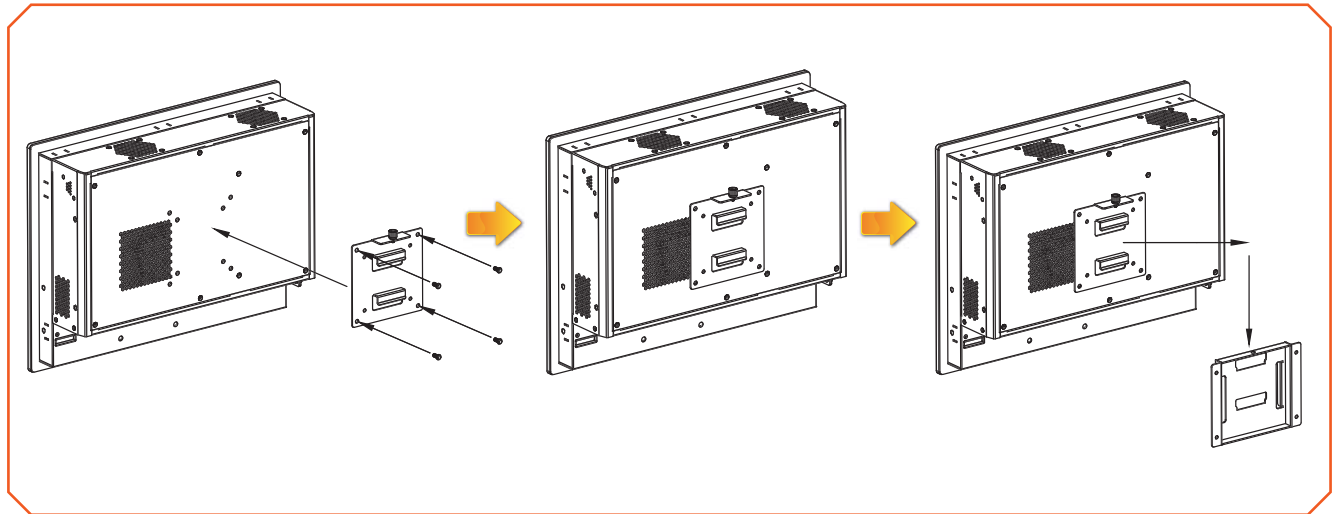

► Panel Mounting

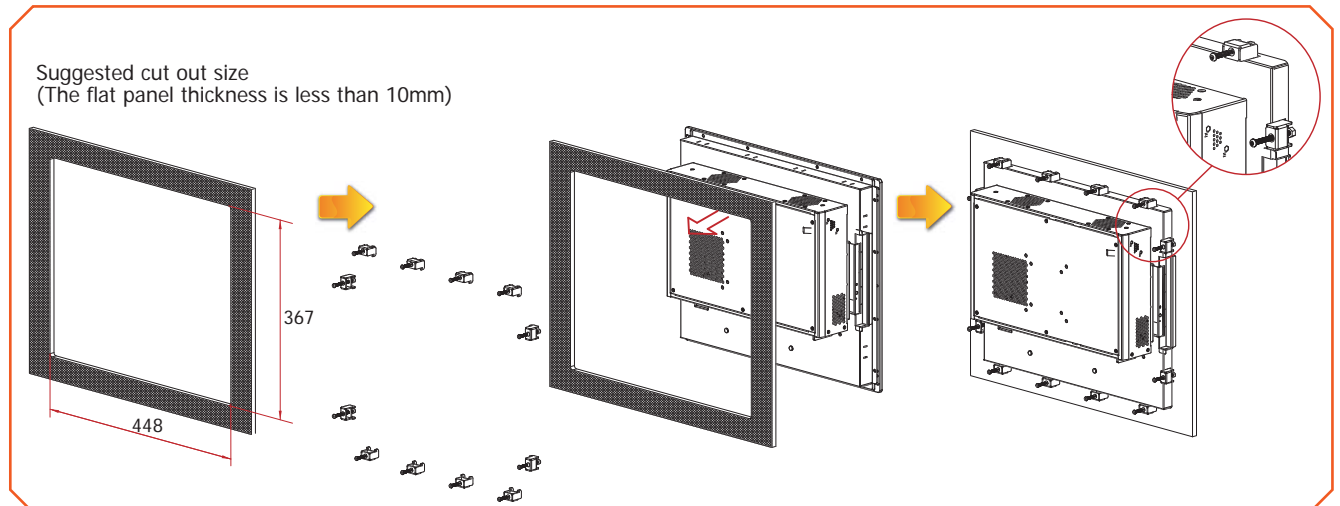

TPC190-SB

▶ Ordering Information

Model Name	Part Number	Description
TPC1902TR-SBACR-R10	750-TPC190-000G	19" Panel PC, H61 chipset, Aluminum Front Bezel, Resistive Touch, AC input, 1 PCIe x1, 1 PCI, 2 Mini PCIe
TPC1902TR-SBACR-R11	750-TPC190-100G	19" Panel PC, H61 chipset, Aluminum Front Bezel, Resistive Touch, AC input, 2 PCI, 2 Mini PCIe
TPC1902TR-SBDCMR-R10	750-TPC190-200G	19" Panel PC, H61 chipset, Aluminum Front Bezel, Resistive Touch, 16~30V DC-in terminal block, 1 PCIe x1, 1 PCI, 2 Mini PCIe
TPC1902TR-SBDCMR-R11	750-TPC190-300G	19" Panel PC, H61 chipset, Aluminum Front Bezel, Resistive Touch, 16~30V DC-in terminal block, 2 PCI, 2 Mini PCIe

▶ Optional Items

Optional Items	Part Number	Description
CPU	785-CP1155DL	CPU, LGA 1155, Long-term support, RoHS
Memory	785-RSOD31G	SODIMM, DDR3, 1GB, RoHS
	785-RSOD32G	SODIMM, DDR3, 2GB, RoHS
	785-RSOD34G	SODIMM, DDR3, 4GB, RoHS
HDD	785-H25250G	2.5" SATA HDD, 250GB, RoHS
	785-H25500G	2.5" SATA HDD, 500GB, RoHS
Power Cord	785-PWRD	Power cord, Standards (USA/EUR/CH), 1.8m, RoHS
Wall Mount	785-PPCWMK	Standard Panel PC Wall Mount kit
Panel Mount	785-190PMK	19" Panel PC Panel Mount kit
DVD-ROM	785-STDDRW	Slim Type SATA DVD-RW/DVD ROM
CD-RW ROM	785-STCDRW	Slim Type SATA CD-RW/DVD ROM

▶ Packing List

- 1 TPC190 Touch Panel PC
- 1 120W power adapter (only for model TPC-1902TR-SBDCMR-R10 and TPC-1902TR-SBDCMR-R11)
- 1 Quick Installation Guide
- 1 CD disk includes drivers/manual

Bright

Dim

Bright/Dim Switch for Sunlight Readable Display (optional)

Applications:
 - Marine
 - Outdoor applications:
 POS, ATM, etc.